

# Technology Student Association Competition 2009 – 2010



## Level One Rule Modifications

# 2009-2010 NYSTSA

## EXECUTIVE COMMITTEE

### STATE OFFICERS

Larry Ge	President	Ithaca High School
Dustin Gibian	Vice President	Lehman Alternative High School
Courtney Elliott	Secretary	Harpursville Central School
Frank Affronti	Treasurer	Wayne Central School
Hannah DeJong	Reporter	Ithaca High School
CodyRyan Dickhaut	Sergeant-At-Arms	Harpursville Central School

### CORPORATE MEMBER AND STATE ADVISORS

Eric Suhr, Corporate Member  
Phil Dettelis, State Advisor  
Evie Weinstein, State Advisor

### ADVISORS

Mr. Mike Giallombardo	Gates-Chili High School
Mr. Mike Elliot	Wayne Central School
Mr. Jay Gauthier	Wayne Central School
Mr. David Buchner	DeWitt Middle School
Mr. Bruce Salisbury	Harpursville Central School
Mr. Terry Kurtz	Odessey Academy
Mr. Derek DeMass	Wayne Central School
Dr. James Carroll	Clarkson University
Mr. Charles Goodwin	NYSTEA
Mr. Clarke Green	Buffalo State University

### NYSTSA BOARD OF TRUSTEES

Mr. Jay Gauthier, teacher/ advisor	Wayne Central School
Mr. Bruce Salisbury, teacher/ advisor	Harpursville Central School
Mr. Tom Kubicki, NYSTEA Association Rep.	SUNY Oswego
Mr. Mike Elliot, Teacher/ advisor	SUNY Oswego

## FORWARD

The diverse competitive events that are listed within this booklet are open to NYSTSA chapters registered to compete in the NYSTSA Competition. The competition will be held at SUNY Oswego on Friday March 26th and Saturday March 27, 2010. This packet contains the competitive events in alphabetical order, the maximum number of participants or teams permitted to compete in each event and, the names and contact information of the event coordinators.

As part of membership in NYSTSA every chapter must affiliate with National TSA. When you affiliate with National TSA <[www.tsaweb.org](http://www.tsaweb.org)> you will be sent the TSA Total TSA CD-ROM. This contains CDs with all the information you will need for membership, competitive events rules and leadership activities. Other than the few events that are unique to NY only modifications that depart from the National guidelines are provided in this packet. To ensure that your chapter meets all NYSTSA guidelines substitute the NY modifications in this packet for the corresponding number or letter on the national guidelines. The paragraph below, from the national website, explains the event rules.

The competitive events program for the 32nd National TSA Conference is governed by the *2009 & 2010 High School Technology Activities, National TSA Conference Competitive Events Guide* (on CD) and the *2010 & 2011 Middle School Technology Activities, National TSA Conference Competitive Events Guide* (on CD). These Events Guides are part of the TSA CD-ROM set and are available from National TSA and include specifications for every event scheduled for the conference in Baltimore, Maryland. Entries for all national competitive events must follow the rules and regulations found in the current middle school and high school *Competitive Events Guides* in the TSA CD-ROM. An overview of all events can be found at <<http://tsaweb.org/Competitions>>.

It is the hope of the student officers, their advisors and the Board of Trustees that this guide will enable students, competitive event judges, and teachers/advisors to better prepare for this exciting competition.

Any questions may be directed to Ms. Evie Weinstein at <[nystsa1@yahoo.com](mailto:nystsa1@yahoo.com)>.

## General Rules Governing Competitive Events

### I. MIDDLE SCHOOL EVENT AND EVENT COORDINATORS

ON-SITE JUDGING*	PRE-COMPETITION JUDGING**
Catapult (Simple Machines) Challenge*** Bruce Salisbury: eagle-3@netzero.net	Graphic Design Jay Gauthier: jgauthier@wayne.k12.ny.us
Dragster Design Jay Gauthier: jgauthier@wayne.k12.ny.us	Lights, Camera, Action Mike Elliott: melliott@wayne.k12.ny.us
Engineering Structure Bruce Salisbury: eagle-3@netzero.net Mike Ramsden: Mramdsen@hcs.stier.org	Multimedia Production Jay Gauthier: jgauthier@wayne.k12.ny.us
Flight Challenge Derek DeMass: ddemass@wayne.k12.ny.us	Website Design Michael Giallombardo: mr_g14625@yahoo.com
Junior Solar Sprint*** David Buchner: dbuchner@icsd.k12.ny.us	
Mouse Trap Vehicle*** Bruce Salisbury: eagle-3@netzero.net	
Prepared Speech Evie Weinstein: nystsa1@yahoo.com	
Problem Solving David Buchner: dbuchner31@hotmail.com	
Technical Drawing Michael Giallombardo: mr_g14625@yahoo.com	
Write Now! Technical Writing Judith Belt: judith.belt@oswego.edu	
ZAP IT! Electrical Applications Mark Hardy: mark.hardy@oswego.edu	

**\*On-Site Judging:** Events that are either prepared at the home school and judged at competition **OR** completed entirely on-site at competition. See individual event descriptions for detail.

**\*\*Pre-Competition Judging:** Submitted and judged *prior* to competition.

**\*\*\***These events are unique to New York. Complete rules are in this packet.

## II. PARTICIPATION IN COMPETITIVE EVENTS:

- A. Students must be registered at the State Competition in order to enter and become winners in a competition. Pre-registration is required. There is no walk-in registration.
- B. No substitutions will be accepted after registration closes.
- C. Neither school nor individual names can appear on projects; only ID#s are to be used. Students are automatically assigned an ID# which they will receive at check-in. **This number needs to be on all student projects.**
- D. Projects/entries must be picked up at the time stated in the competition agenda.

## III. COMPETITIVE EVENTS ATTIRE

ALL STUDENTS ATTENDING THE COMPETITION **MUST** wear either official TSA or business casual TSA attire. Your cooperation with this policy will assist in providing a positive image for the organization and its members.

### A. Official TSA attire:

Blazer:	navy blue with TSA patch
Ties/scarves:	official TSA red tie
Shirt or Blouse:	white with collar
Slacks or Skirt:	gray
Shoes:	black dress shoes
Socks:	black or nylon hosiery

### B. Business Casual TSA attire should **minimally** include:

A collared shirt/blouse, or a polo shirt with official TSA logo (no t-shirts), long pants (no shorts, cargo, camo or bluejeans), dresses/skirts, socks/hosiery and appropriate footwear (examples of unacceptable footwear would include flip-flops, beach shoes, crocs).

**Students NOT wearing New York State attire will lose 20 points from total score of each event entered. Hats are NOT permitted.**

## IV. PROPERTY DAMAGE OR LOSS

The College of SUNY OSWEGO and NYSTSA are not responsible for damage to or loss of property brought to the competition.

**Catapult  
Level I  
NYSTSA 2010  
On-Site Judging**

**OVERVIEW:** TSA of New York students entering the Simple Machines event are required to research, design, draw and build a lever machine (catapult) to demonstrate their knowledge of technology and the principles of simple machines.

**EVENT COORDINATOR:** Bruce Salisbury eagle-3@netzero.net

- I. **CONTEST PURPOSE:** To provide a means for TSA members to demonstrate their ability to research, design, draw and build a catapult that illustrates the principle of a lever.
- II. **ELIGIBILITY FOR ENTRY:** Up to three students per team. No limit on entries per chapter.
- III. **LEVELS OF COMPETITION:** Level I and II
- IV. **TIME LIMITATIONS:** Participants must present research material, a complete set of drawings and a technical report at the time specified in the competition program. Catapult must be constructed before arriving at the competition. All participants in this event must arrive and be in place at the specified time and location.
- V. **SPECIFIC REGULATIONS:**
  - A. Entries must be designed and constructed by the student. Contestants may enter only one catapult that has been researched, designed, drawn, and constructed during the current TSA of New York school year.
  - B. Research: A collection of material, which explain the principles of levers as related to the design submitted. May include some pictures.
  - C. Design: Support the principle of simple machines and utilizes research information.
  - D. Drawings: A detail drawing in two views for each part of the catapult that is cut and assembled separately. Must use metric dimensions. Paper no larger than B size with a border and title block as illustrated on the website. Drawings should be developed using standard engineering practices and procedures. The drawings may be produced using traditional drafting methods or CADD. Copies of drawings are acceptable.
  - E. Technical Report: Explanation of overall research involved in designing and constructing the catapult. Must include construction and assembly procedure for the catapult submitted and a description of the launch techniques that should be employed to ensure payload accuracy. Drawings

and diagrams may be used to supplement the report.

F. Target space will be limited to a 4 foot circle.

G. Size of the Catapult project may not be larger than 4 feet cubed. (4ft x 4ft x 4ft)

H. Catapults must use a lever only.

I. The projectile used will be a standard sized Hacky Sack.

#### VI. PROCEDURE:

A. Students will enter the competition before registration deadline.

B. Participants will follow instruction and event timelines provided at registration.

C. Completed research, design and drawings turned in at registration.

D. A pre-launch period is provided so that participants can make adjustments to weights, balance, and fit. Catapults must be returned to the evaluators after the pre-launch period.

E. Each participant is given three opportunities to launch their catapult to a target (X) feet from the starting point, hand launched from the designated location. The closest opportunity to the target is used to determine accuracy points.

#### VII. REQUIRED CONTEST PERSONNEL/ EQUIPMENT;

A. Contest Coordinator

B. Three judges

C. Rating sheets for judges

D. Target

E. Measuring tape

F. Large enclosed area (gym)

G. Triple beam balance

H. Construction material

#### VIII. CRITERIA FOR JUDGING:

A. Research

B. Design

C. Drawings

D. Construction

E. Technical Report

F. Accuracy

#### IX. ACCURACY POINTS

1st place 50 points

2nd place 46 points

3rd place 42 points

4th place 38 points

5th and 6th place 35 points

7th and 8th place 30 points

9th to 12th place 25 points

13th to 16th place 20 points

17th to 18th place 15 points

All other launched 10 points

**Dragster Design**  
**Level I**  
**NYSTSA 2010**  
**On-Site Judging**

Overview:	No change
Challenge:	No change
Eligibility:	Ten individually produced dragsters per chapter.
Time Limits:	No change
Procedures:	Procedure E modification – All cars will be allowed to race. However cars that do not meet specifications will be assessed a 20% penalty for each rules violation. 20% will be deducted from total points earned. Delete D, E, F, G
Regulations:	No change
Evaluation:	Dragster Appearance will be worth 25 points and cars will scored by ranking them similar to race times. No wind tunnel tests
Coordinator:	Jay Gauthier: jgauthier@wayne.k12.ny.us

**Engineering Structure  
Level I  
NYSTSA 2010  
On-Site Judging Event**

Overview:	Bridge design, prepared prior to conference
Challenge:	Device is constructed prior to competition and submitted for destructive testing
Eligibility:	No limit per chapter
Safety:	Bring you own safety glasses for destructive testing.
Time Limits:	A and B. Delete
Attire:	Refer to <b>NYSTSA 2010 Modifications for COMPETITIVE EVENTS ATTIRE</b>
Procedures:	A, B, C, E, F, H, J. Delete D. Participants sketch their design and drop off sketch when they drop off bridge at designated area. Identification number only. No names on device. G. Delete “As each structure is completed”, replace with “At check in...”
Regulation:	B. Delete. See allowable glues below C. (replace C with the following) Teams may use only the following materials. <b>Materials:</b> Up to <b>20’ of 1/8x1/8 balsa wood</b> only, and white glue or yellow carpenters glue D. (replace D with the following) Length of bridge is 12”, abutment span is 10”, 1” of bridge on each abutment (see diagram below), the bridge height must be between 2”and 5”, both sub-structures and super-structures are allowable-as long as they do not exceed maximum height, see definitions and allowable heights below. The bridge may not exceed 3” wide E. No change F. No change (*see lamination diagram below) G. No change (test rod is 1/2” threaded rod) H. Video recording is permitted for any entry I. Delete

Evaluation:	A, C, D. No change B. The test block will be a piece of 3/4" wood, 2" x 8" with a 1/2" hole in the center to accept the threaded rod.
Coordinator	Bruce Salisbury: eagle-3@netzero.net Mike Ramsden: Mramdsen@hcs.steir.org

Length = 12"

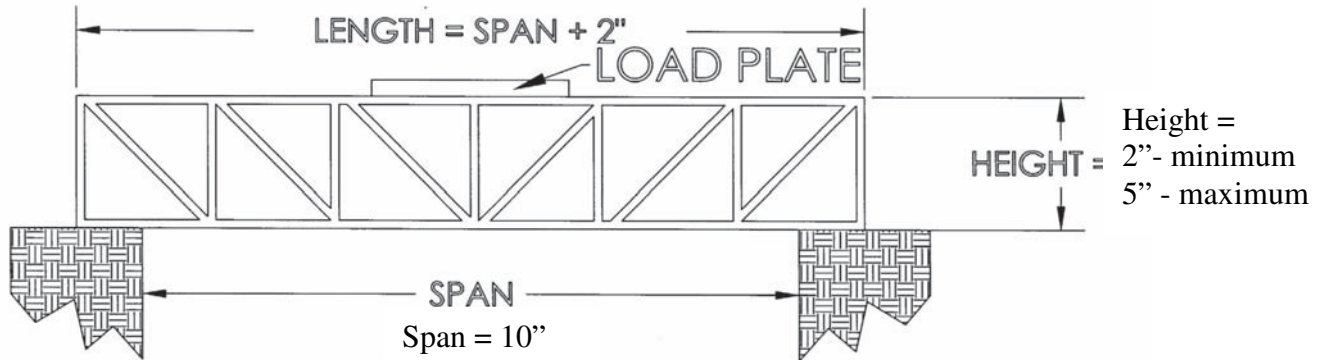

**\*Please read the national rules completely and bring your own eye protection for destructive testing at the competition.\***

\*Sub-structure: That part of the bridge that is constructed under the road bed.

\*Super-structure; That part of the bridge that is constructed above the road bed.

## **Laminations Visualized**

### **CORRECT LAMINATION**



### **INCORRECT LAMINATION**



**Flight  
Level I  
NYSTSA 2010  
On-Site Judging**

Overview:	Planes are not built at the competition
Challenge:	Planes are not built at the competition, no construction materials provided.
Eligibility:	Seven (7) entries per chapter, one entry per individual.
Time Limits:	A. Delete Participants are provided a minimum of fifteen (15) minutes for trim flights at the event site.
Procedures:	B, C Delete
Regulations:	A, B, E. Delete
Evaluation:	No Change
Coordinator:	Derek DeMass: <a href="mailto:ddemass@wayne.k12.ny.us">ddemass@wayne.k12.ny.us</a>

**Graphic Design**  
**Level I**  
**NYSTSA 2010**  
 Pre- Competition Judging

Overview:	Participants plan and lay out a graphic design that promotes the New York State Technology Student Association.
Challenge:	Create and produce a one (1)-color graphic design that is appropriate for printing on NYSTSA competition T-shirts and other small promotional items. The design must promote NYSTSA
Eligibility:	Five (5) individuals per chapter. All entries must be accompanied by TSA Photo/Film/Video release found in the 2010 National TSA Events guide.
Time Limits:	Pre-site Judging Entries must be post-marked by February 26, 2010
Procedures:	A. Pre-site Judging Entries must be post-marked by February 26, 2010 C. Winning design may be screen printed on T-shirts that will be on display at the NYSTSA competition at Oswego
Regulations:	D. Design must promote NYSTSA H. refers to state competition
Evaluation:	Pre-site Judging all entries must be sent to Jay Gauthier: 6076 Ontario Center Rd./ PO Box 155/ Ontario, NY 14520-0155 Entries must be post-marked by February 26, 2010
Coordinator:	Jay Gauthier E-mail: <a href="mailto:jgauthier@wayne.k12.ny.us">jgauthier@wayne.k12.ny.us</a>

**Junior Solar Sprint**  
**Level I**  
**NYSTSA 2010**  
On-Site Judging

3 vehicles/chapter, up to 4 individuals per team

The Northeast Sustainable Energy Association provides the standard rules. *In addition to these rules the teams must also provide design portfolio &/or sketches as evidence of the student design process.* Please note: a final working drawing would NOT show the design process!

EVENT COORDINATOR: David Buchner: dbuchner@icsd.12.ny.us

**Materials and vehicle specifications:**

1. The Ray Catcher solar panel sold by Pitsco and the JSS Solar Panel sold by Solar World may be used. Panels cannot be shaved, drilled or delaminated. The motors supplied with these panels (Mabuchi #280-2865 and Mabuchi #260-18130) may be used. Motors may not be re-wound or disassembled. Solar panels used in 1995-2005 and motors used in 1996-2005 may be re-used this year as well. Any other panels and motors may not be used in the competition. All parts mentioned here must be used without modification. One solar panel and one motor allowed per car. However, reflectors, supports, and power leads may be added to these components.
2. The remainder of the vehicle can be made from any other materials.
3. The vehicle may not be larger than 30 cm. (12 in.) wide by 60 cm. (24 in.) long by 30 cm. (12 inches) high.
4. The solar vehicle must be structurally sound without the solar panel. The solar panel must be able to be removed from the vehicle, and easily disconnected from the motor.
5. A 2 cm x 2 cm surface must be available for the car number, which should be easily visible when the vehicle is in the ready to race position.
6. The vehicle must be designed with a compartment to carry a payload of 1 empty 12 oz. aluminum soda can. The can may not be part of the vehicle's structure, and must be easily and rapidly removed or reinserted. The can will be supplied by NYSTSA before the start of the race, and must remain with the vehicle and unaltered during the entire event, and returned to the judges following the race if requested.
7. The vehicle must be powered solely by the sun's energy. No energy storage devices (e.g. flywheel battery, etc.) may be used in conjunction with the solar panel.

8. If the sun's energy is judged insufficient, a battery pack will be furnished for each race. Motor power leads should be readily accessible for easy attachment to a battery pack. Each contestant must bring two of their own double A (AA) alkaline batteries. Battery holders will be supplied by the Event Coordinator.

9. The vehicle will be steered via a guide wire that runs the length of the track (typically fishing line). The vehicle must be attached to the guide wire by a minimum of 1 attachment point. The vehicle must be easily attached (and removed) from the wire without disconnecting the guide wire.

10. The vehicle must be of student's own design and manufacture from the current school year; no car or major part thereof from a previous year shall compete. Each team from a given school must have a unique car design.

### **The Race Track**

11. The race lane is 60 cm. wide and 20 meters long. The track is a hard flat surface such as an asphalt tennis court or running track. The track can be oriented in any direction (e.g. North-South, East-West, etc.)

12. The guide wire will be located in the center of the lane. The wire will be no higher than 1.5 cm. above the track surface. The wire will be small diameter line, such as fishing line (e.g. 60# test monofilament). There will be no free end on the guide wire, thus the cars must be hooked into the wire, not strung onto it.

### **Conduct of the Race**

13. The races will be run in a double elimination format. Thus you will have a minimum of two opportunities to race before you are eliminated from competition.

14. Only two members of the race team will be allowed on the track during the race: one at the starting line and one at the finish line. A non-team member may act as a catcher if necessary. Student non-team members will be chosen over adult non-team members if possible.

15. Each vehicle must have an assigned student team captain. No student shall be assigned team captain to more than one vehicle. No team shall consist of more than four students.

16. The vehicle will start from behind the starting line with all wheels touching the track. The solar panel will be covered by an opaque sheet, which will be held above the panel by a member of the race team to block the sunlight. The vehicle should not be touched by the sheet or by any member of the team at this time. When the line judge gives the signal to start the race the team member will remove the sheet so the panel will be exposed to the sunlight.

17. There will be a 5-minute time limit to prepare your vehicle to race in your lane. This should be sufficient time to attach the vehicle to the guide wire. The race will start at the end of this time limit regardless of whether the vehicle is ready to compete.

18. Once the race has begun team members are not allowed to touch their vehicle or be on the race lanes until their vehicle has crossed the finish line and the judges have determined the heat completed. Pushing the vehicle after the race has begun may result in disqualification or a re-run of the race.

19. Any car that leaves its lane will be disqualified from the heat in question. However, the offending vehicle may compete in its second trial if not having done so already. If the car leaving its lane interferes with any other cars those cars whose run was interfered with will be allowed an additional opportunity to run.

20. Loss of payload during a race will result in disqualification from the heat in question. However, the offending vehicle may compete in its second trial if not having done so already. If the loss of payload interferes with any other cars those cars whose run was interfered with will be allowed an additional opportunity to run.

21. Winner of a heat will be the first vehicle to cross the finish line or the vehicle to travel the farthest down the track. Generally speaking, the top two finishers will advance to the next heat. In the event of a tie, the judges may determine multiple winners, and admit additional cars to advance to the next round of competition.

22. Awards will be given for speed and technical merit.

### **Advancement from Area to Regional Competition**

23. Each area will be allowed to send at least six cars to the regional competition. The total number of invitations is based on the number of competing teams and will be determined by the Northeast Sustainable Energy Association.

24. It is left up to the area event coordinators to determine the eligibility requirements for filling that quota, and which teams will be invited to advance to the Northeast Regional Championship.

25. Only Level I contestants may advance to the regional competition.

**Lights, Camera, Action**  
**Level I**  
**NYSTSA 2010**  
 Pre-competition Judging

Overview:	You must create a music video to promote Technology Education. Music must be a popular song from the 1980s.
Challenge:	No written test
Eligibility:	Individuals or teams up to 3 are acceptable. Unlimited teams per chapter
Time Limits:	Music videos do not need to be the entire length of the song but should be at least 2 minutes 30 seconds. Be sure the DVD plays in a standard DVD player.
Procedures:	A, C & D. Delete
Regulations:	This is a pre-judged event. The DVD and paperwork must be mailed to:  <b>Michael Elliott</b> <b>James A. Beneway High School</b> <b>Ontario Center, NY 14520</b>  These items must be postmarked no later than March 6, 2010. Items postmarked after the given date will be disqualified.
Evaluation:	No Change
Coordinator:	Michael Elliott: mellott@wayne.k12.ny.us

## **Mouse Trap Vehicle**

### **Level I**

### **NYSTSA 2010**

#### **On-Site Judging**

**OVERVIEW:** NYSTSA students entering this event are required to design, draw, and build a mousetrap powered vehicle to demonstrate their knowledge of Technology and the principles of energy transfer.

**EVENT COORDINATOR:** Bruce Salisbury at eagle-3@netzero.ne

**I. CONTEST PURPOSE:** To provide a means for TSA members to demonstrate their ability to design and construct a working vehicle within a set of specifications.

**II. ELIGIBILITY FOR ENTRY:** Individual event, no limit on number of entries per chapter.

**III. LEVELS OF COMPETITION:** Level II.

**IV. TIME LIMITATIONS:** 8 minutes

#### **V. SPECIFIC REGULATIONS:**

- A. Entries must be designed and constructed by the student. Contestants may enter only one vehicle that has been designed and constructed during the current TSA of New York year. NO KITS.
- B. Only one standard mousetrap (single spring 5x10cm) may be used. Although it may be altered, no alteration to the energy-storing capacity (the spring) is allowed. The "vehicle" must be a self contained unit and move as a whole.
- C. The total energy used by the vehicle during the race must come from only the mousetrap spring. While other energy storage is permissible it must be powered up by the mousetrap. (Ex. a rubber band could be used in the vehicle but must not be stretched or twisted at the beginning of the race. If fishing rods are used they cannot be bent or loaded with energy prior the start of the race.
- D. The race will be on a smooth surface.
- E. Drawings: Every entry must submit a full size or scaled drawing of the completed vehicle. A two-view (top and side) drawing with English standard dimensions shall be made on paper no larger than B size with a border and title block as illustrated in the title border section. Drawings should be developed using standard engineering practices and procedures. The drawings may be produced using traditional drafting methods or CADD. Copies of drawings are acceptable.
- F. Technical report: Explanation of overall design consideration and materials used to construct the vehicle. The report must include theory(s) of energy transfer and a description of the launch techniques that should be employed to

ensure a successful run. Drawings and diagrams may be used to supplement the report.

**VI. PROCEDURE:**

- A. Students will enter the competition before the registration deadline.
- B. When it is the students' turn, they will place the loaded vehicle with the spring centered on the starting line and release it. It must be started by the normal release mechanism of the mousetrap. (No push may be given to the vehicle by the student).
- C. The student will be given two trial runs, with the average score of travel distance and travel time being used for the judging. If the student cannot get the vehicle in operation within a reasonable time (2minutes), that trial will be scored a zero for the distance traveled and a minus 120 points for travel time.

**VII. REQUIRED CONTEST PERSONNEL/ EQUIPMENT:**

- A. Contest Coordinator
- B. Three judges
- C. Rating sheets for the judges
- D. Two stop watches
- E. 100' Tape measure
- F. Smooth surface (corridor, gym floor)

**VIII. CRITERIA FOR JUDGING:**

- A. Design 10 points
- B. Drawing 30 points
- C. Construction 30 points
- D. Technical Report 20 points
- E. Distance Unlimited points
- F. Travel time Limited to minus 120 points
- TOTAL Unlimited points

*NOTE:*

*Distance, the point the vehicle stops moving (3 points per foot, measured to the nearest inch. Distance will be measured perpendicular to the starting line to the center of the spring).  
Travel time (minus 1 point per second, measured to the 0.01 second. Timing will be from the instant of trigger release to the instant the vehicle ceases motion).*

**Multimedia Production**  
**Level I**  
**NYSTSA 2010**  
 Pre- Competition Judging

Overview:	Participants use their creative skills to produce a multimedia presentation that promotes the theme - " <b>What is TSA?</b> " (Design to inform school administrators why they should support NYSTSA in their schools)
Challenge:	Create and design a stand-alone multimedia presentation to promote NYSTSA. (Design your presentation to inform School administrators why they should support NYSTSA in their schools)
Eligibility:	<b>Only 5 students from each chapter can enter.</b> Entries may be five individual entries or group collaborative entries composed of three students or less.
Time Limits:	Pre-site Judging entries must be post-marked by February 26 <sup>th</sup> 2010. Presentation must not exceed 3 minutes.
Procedures:	<b>A.</b> Entries must be post-marked by February 26 <sup>th</sup> 2010. <b>Presentation may not exceed 3 minutes.</b> <b>C, D, E, and F</b> eliminated. The winning entry may be presented at the NYSTSA conference in Oswego and may also be shared with school districts throughout New York State to promote the formation of new NYSTSA chapters.
Regulations:	Regulation B-6 modification changed to - <b>May not exceed 3 minutes.</b> Regulation C modification - optional/ <b>not required</b>
Evaluation:	Pre-site Judging all entries must be sent to Jay Gauthier: 6076 Ontario Center Rd./ PO Box 155/ Ontario, NY 14520-0155 Entries must be post-marked by February 26, 2010.
Coordinator:	Jay Gauthier E-mail: jgauthier@wayne.k12.ny.us

**Prepared Speech**  
**Level I**  
**NYSTSA 2010**  
**On-Site Judging**

Overview:	<p>The NYSTSA 2010 topic will be: “Energy production and the environment”. Students must incorporate the 2010 National TSA Conference theme of “TSA: Tomorrow's Leaders” <u>as it applies to New York state</u>, and should address both positive and negative perspectives of emerging <u>and</u> fossil fuel-based energy sources.</p> <p>Useful Research Links: <b><a href="http://www.nyserda.org">www.nyserda.org</a></b>  <b><a href="http://www.fossil.energy.gov/programs/oilgas/index.html">www.fossil.energy.gov/programs/oilgas/index.html</a></b> [US Dept. of Energy]  <b><a href="http://www.communityscience.org/gaswells.html">www.communityscience.org/gaswells.html</a></b>  <b><a href="http://www.shaleshock.org/drilling-101/">www.shaleshock.org/drilling-101/</a></b>  <b><a href="http://www.eere.energy.gov/">www.eere.energy.gov/</a></b></p>
Challenge:	No change
Eligibility:	Unlimited
Time Limits:	No change
Procedures:	E, F, G. Delete. (there are no semifinalists).
Regulations:	B. Delete
Evaluation:	Evaluation is based upon the quality, content and effectiveness of the presentation, as well as the speaker's stage presence.
Coordinator:	Evie Weinstein: <a href="mailto:nystsa1@yahoo.com">nystsa1@yahoo.com</a>

**Problem Solving  
Level I  
NYSTSA 2010  
On-Site Judging**

Overview:	No change
Challenge:	No change
Eligibility:	Three teams of two students per chapter.
Time Limits:	No change
Procedures:	E. Delete (there are no finalists)
Regulations:	C. Delete Participants bring their own tool kits.
Evaluation:	No change
Coordinator:	David Buchner: dbuchner@icsd.k12.ny.us

**Technical Drawing**  
**Level I**  
**NYSTSA 2010**  
On-Site Judging

Overview:	No semifinalists
Challenge:	No change
Eligibility:	Three individuals per chapter.
Time Limits:	A. Delete
Procedures:	No written test, no semifinalists.
Regulations:	A. Delete (no written test)
Evaluation:	A. Delete
Coordinator:	Michael Giallombardo: mr_g14625@yahoo.com

**Website Design  
Level I  
NYSTSA 2010  
Pre- Competition Judging**

Overview:	No on-site interview
Challenge:	No change
Eligibility:	Unlimited entries per chapter
Time Limit:	B. URL must be submitted to <b>nystsa_cyberspace@yahoo.com</b> by midnight Friday March 12, 2010. All emails will be time stamped which will serve as proof of submitting project by deadline. C. Delete
Procedure:	A, B, C, D, E, F, G, H. Delete
Regulations:	B, C, E, G. Delete
Evaluation:	B. Delete
Coordinator:	Michael Giallombardo: mr_g14625@yahoo.com

**Write Now! Technical Writing**  
**Level I**  
**NYSTSA 2010**  
On-Site Judging

Overview:	<p>NYSTSA topic: "New York has many natural resources, among them vast quantities of natural gas reserves stored in a geologic region known as the Marcellus Shale. Gas companies are poised to drill into this area to recover the gas. Discuss the impacts this will have, both positive and negative, on our energy needs, our economy and our environment.</p> <p><u>Useful Research Links:</u>  <a href="http://www.nyserda.org">www.nyserda.org</a>  <a href="http://www.fossil.energy.gov/programs/oilgas/index.html">www.fossil.energy.gov/programs/oilgas/index.html</a> [click on <a href="#">Modern Shale Gas Development in the United States: A Primer</a>]  <a href="http://www.shaleshock.org/drilling-101/">www.shaleshock.org/drilling-101/</a></p>
Challenge:	No change
Eligibility:	Unlimited
Time Limits:	No change
Procedures:	A. No subtopics. Limit of one (1) note card. C, D, E delete. F. Four (4) pages. H. delete
Regulations:	A. No subtopics. E. Four (4) pages. H. Winning entries may be submitted to NYSERDA and/or the NYS Department of Environmental Conservation
Evaluation:	No change
Coordinator:	Judith Belt: <a href="mailto:judith.belt@oswego.edu">judith.belt@oswego.edu</a>

**ZAP IT! Electrical Applications**  
**Level I**  
**NYSTSA 2010**  
 On-Site Judging

Overview:	Through a written test and a circuit construction task, the participants will demonstrate basic electrical knowledge, electronic theory, and tool use. The participants will assemble a circuit on site. Participants will demonstrate a basic understanding of resistors, capacitors, transistors, wire, switches, 555 timer IC, a speaker, LEDs, and a circuit boards.
Challenge:	The participants will demonstrate their electrical knowledge through the construction of an electronic circuit on site from a provided schematic and components kit, make some basic measurements, and answer questions about the circuit.
Eligibility:	Participants are limited to two individuals per chapter.
Time Limits:	Participants will have two hours to complete the written and laboratory portions of the competition.
Procedures:	All tools and materials will be provided for participants at the competition. Participants will not be required to bring any tools or supplies. Participants will be required to provide their own safety glasses.  <b>The following will be provided to each participant:</b> Soldering Iron; Wire Cutters; Needle Nose Pliers; Masonite Board (To protect the bench tops); Desoldering Pump (as needed); Rosin Core Solder; Electronic component kit containing resistors, capacitors, transistors, wire, switches, 555 timer IC, a speaker, LEDs, and a circuit board.

Regulations:	<ol style="list-style-type: none"> <li>1. Participants are required to be present during the entire competition time. They must remain in their appointed workstation until they are told that they can move by the event coordinator. Any participant who leaves the competition room will forfeit their entry into the competition.</li> <li>2. Participants may not communicate with instructors, parents, or other participants during the competition.</li> <li>3. Reference materials, notebooks, textbooks, cameras, and other electronic devices are not allowed in the competition area.</li> <li>4. Personal tools, meters, or other materials will not be allowed. All competition materials will be provided except for safety glasses.</li> <li>5. Proper safety practices must be followed at all times. Participants must provide and wear their own safety glasses with side shield at all times when in the lab. Prescription glasses must have side shields or goggles must be worn over the glasses.</li> <li>6. Participants must maintain and exhibit a positive and professional attitude at all times consistent with TSA standards</li> <li>7. Competition materials may not be taken from the competition area.</li> <li>8. Food and Drinks will not be allowed in the work areas.</li> </ol> <p>Failure to adhere to these rules will result in disqualification from the competition.</p>
Evaluation:	<p>Completed circuits will be evaluated for accuracy, function, and correct assembly techniques. Electrical and electronics knowledge will be evaluated through written responses to general electronics knowledge and questions specific to the circuit being constructed.</p>
Coordinator:	<p>Dr. Mark Hardy: mark.hardy@oswego.edu</p>

# Registration Forms

Complete and mail with  
payment to:

Evie Weinstein  
NYSTSA State Advisor  
376 Brooktondale Rd  
Brooktondale, NY 14817

## Cost

Post marked before March 5<sup>th</sup>

\$25 per student

Between March 6<sup>th</sup> and 12<sup>th</sup>

\$30 per student

This includes banquet

Registration closed after March 12<sup>th</sup>

**NO WALK-IN REGISTRATION**

Make Checks Payable to: NYSTSA

Sorry, no credit cards or purchase orders  
accepted



# Level One Registration

#	Student (last, first)	Catapult	Dragster Design	Engineering Structure	Flight	Graphic Design	Junior Solar Sprint	Lights, Camera, Action	Mouse Trap Vehicle	Multimedia Production	Prepared Speech	Problem Solving	Technical Drawing	Website Design	Write Now! Technical Writing	Zap It! Electrical Applications
-	Entries per Chapter ->>	UT of 3	10/c	U	7	5	3T of 4	UT of 3	U	5ind or ToF 3	U	3T of 2	3	U	U	UT up to 3
1																
2																
3																
4																
5																
6																
7																
8																
9																
10																
11																
12																
13																
14																
15																
16																
17																
18																
19																
20																
22																
COST \$25 per student before 3/5/10, \$30 between 3/6/10 and 3/12/10, no registration after 3/12/10																
Number of Students		Registration Fee (\$25 or \$30)		Fee For Additional Banquet Guests		Total Enclosed	\$									